

Magnetic Lock Wiring Instructions

A. 12VDC Input:

Required power 0.5 amp (Maximum).

Connect the ground (-) lead from a 12VDC power source to terminal 2

Connect the positive (+) lead from a 12VDC power source to terminal 1.

Check jumper for 12VDC operation.

B. 24VDC Input:

Require power 0.25 amp (Maximum).

Connect the ground (-) lead from a 24VDC power source to terminal 2

Connect the positive (+) lead from a 24VDC power source to terminal 1.

Check jumper for 24VDC operation.

C. Contacts:

Relay dry contacts are rated 1 amp at 24VDC for safe operation, do not exceed this rating.

If you require a normally open switch, connect the wires from the system to terminal 4 and terminal 3.

If you require a normally closed switch, connect the wires from the system to terminal 4 and

terminal 5.

Important!

1. The product should only be powered by a UL listed power supply.
2. If power switch is not wired between DC source voltage and magnet, it will take a longer time to de-energize the magnet simulating residual magnetism. (see below)

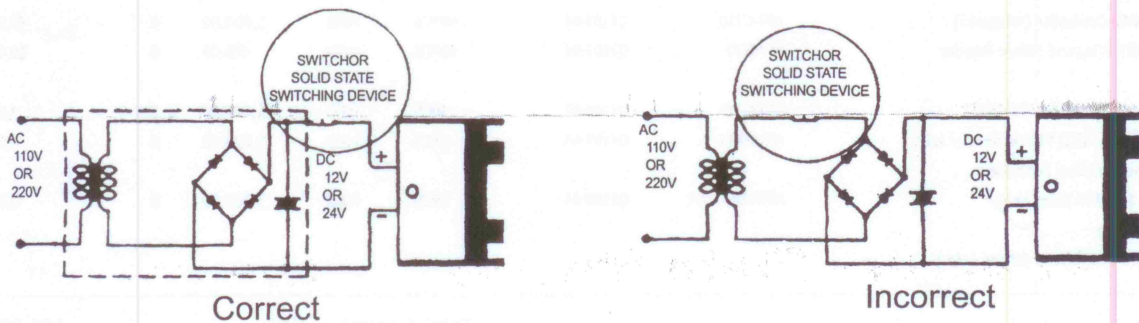

Printed Circuit Board Schematic

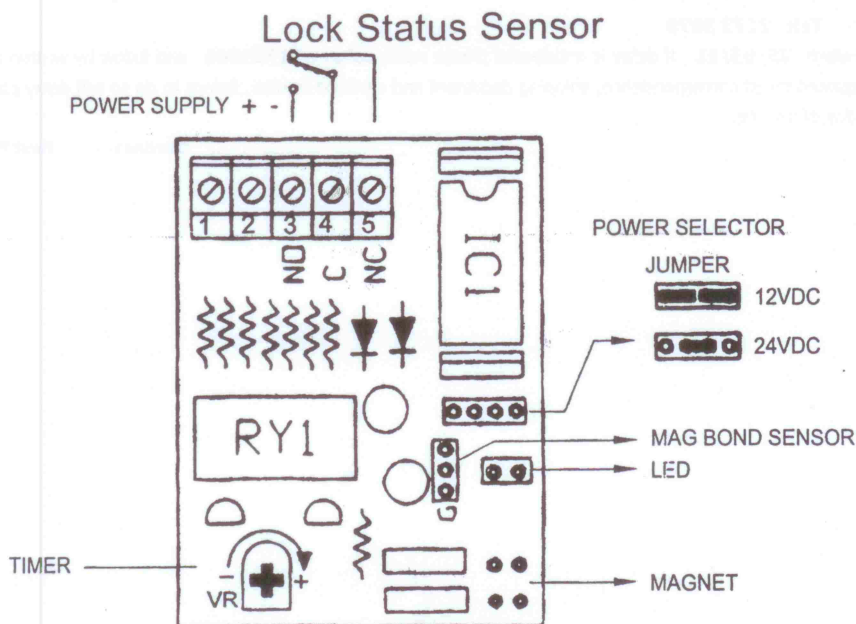

Instructions For Magnetic Locking Devices

Important: Please Read Before Attempting To Install Magnetic Lock

- Handle the equipment with care, damaging the mating surfaces of the magnet or armature plate may reduce locking efficiency.
- The magnet mounts rigidly to the door frame, The armature plate mounts to the door with hardware. Kit provided that allows it to pivot about its center to compensate for door wear and misalignment.
- Template use must take place with the door in its normally closed position.
- Firmly tighten all screws.

Typical Installation:

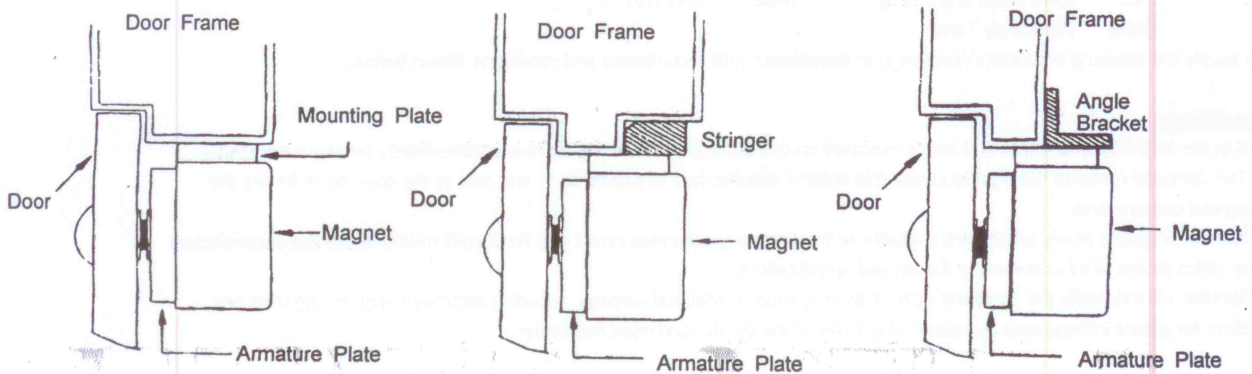

Armature Plate Mounts To The Door

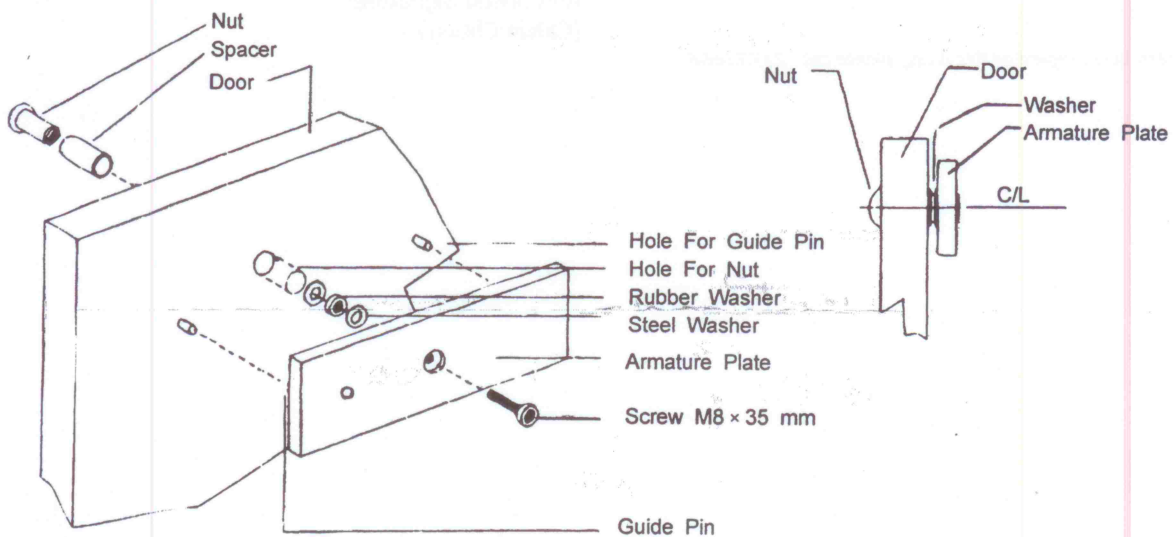

****Important:** Fix the armature plate not too tightly, and make the rubber washer more flexible, in order to make the armature plate automatically adjust its proper position with the magnet.